

L2624 Rev. A 12/04

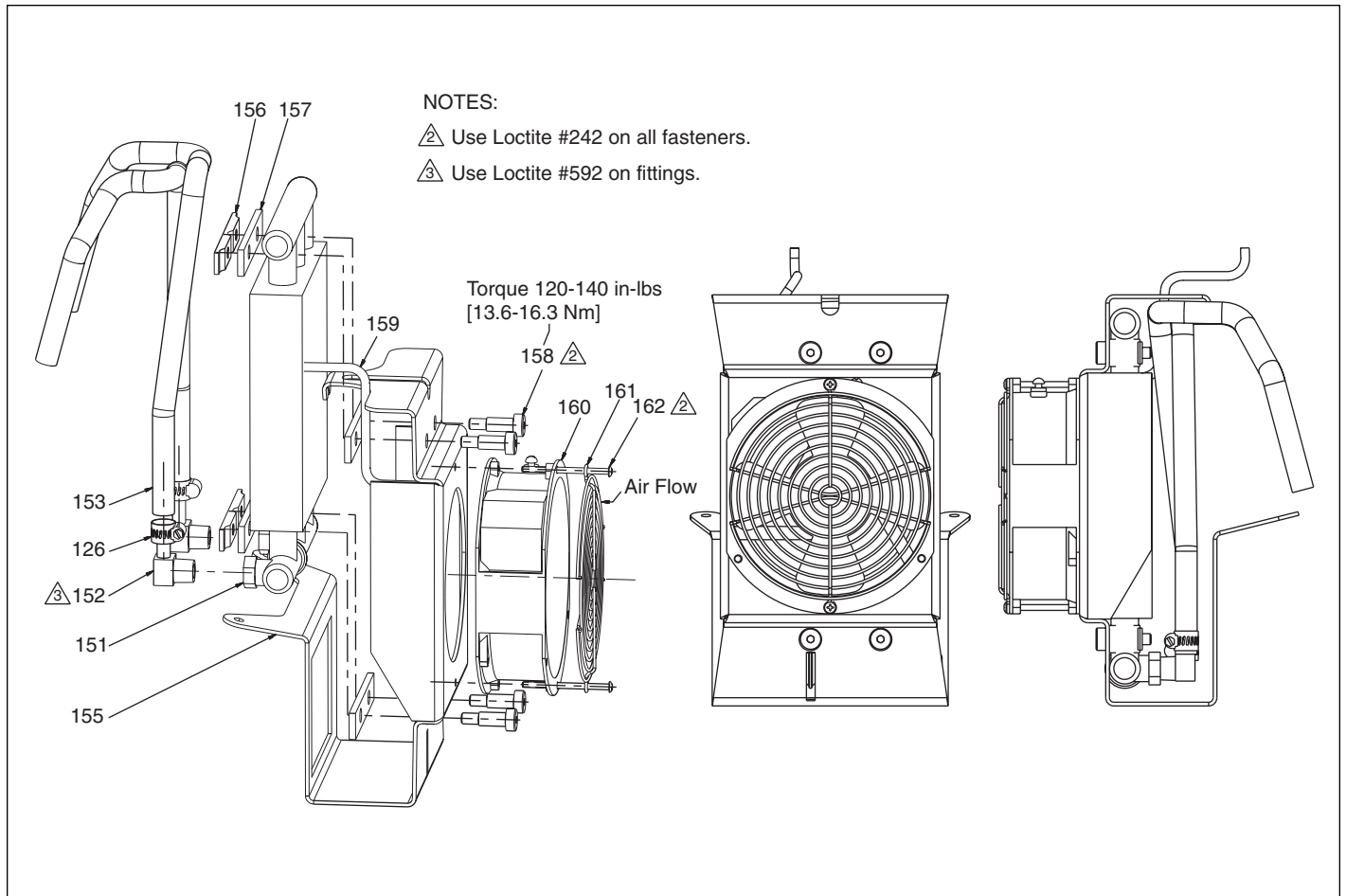

Figure 1, Heat Exchanger

Repair Parts List, Heat Exchanger

Item	Part Number	Qty.	Description	Item	Part Number	Qty.	Description
126	★ DC9639299	4	Hose clamp 3/8 X 7/8	157	★ DC9554037	4	Gasket
151	★ DC9546471	1	Heat Exchanger coil	158	★ DC9576242	4	Shoulder Bolt M8 x 20
152	★ PA2029097	2	Hose Barb Elbow	160	†★DC3224900SR	1	Fan Asm. 24V
153	★ DC9417646	2	Hose 19"	161	†★DC3227689	1	Fan Guard
155	★ DC9545471	1	Bracket	162	†★DC9575628	2	Bolt #8-32 x 2.50
156	★ DC9555471	2	Bracket				

★ Items included in Kit ZHE-U4

† Items included in Service Repair Kit DC3224900SR

NOTE: Enerpac does not provide the pin connector as a service part.

Use: AMP Housing #770849-2, 1 piece

AMP Pin #640706-1, 2 pieces

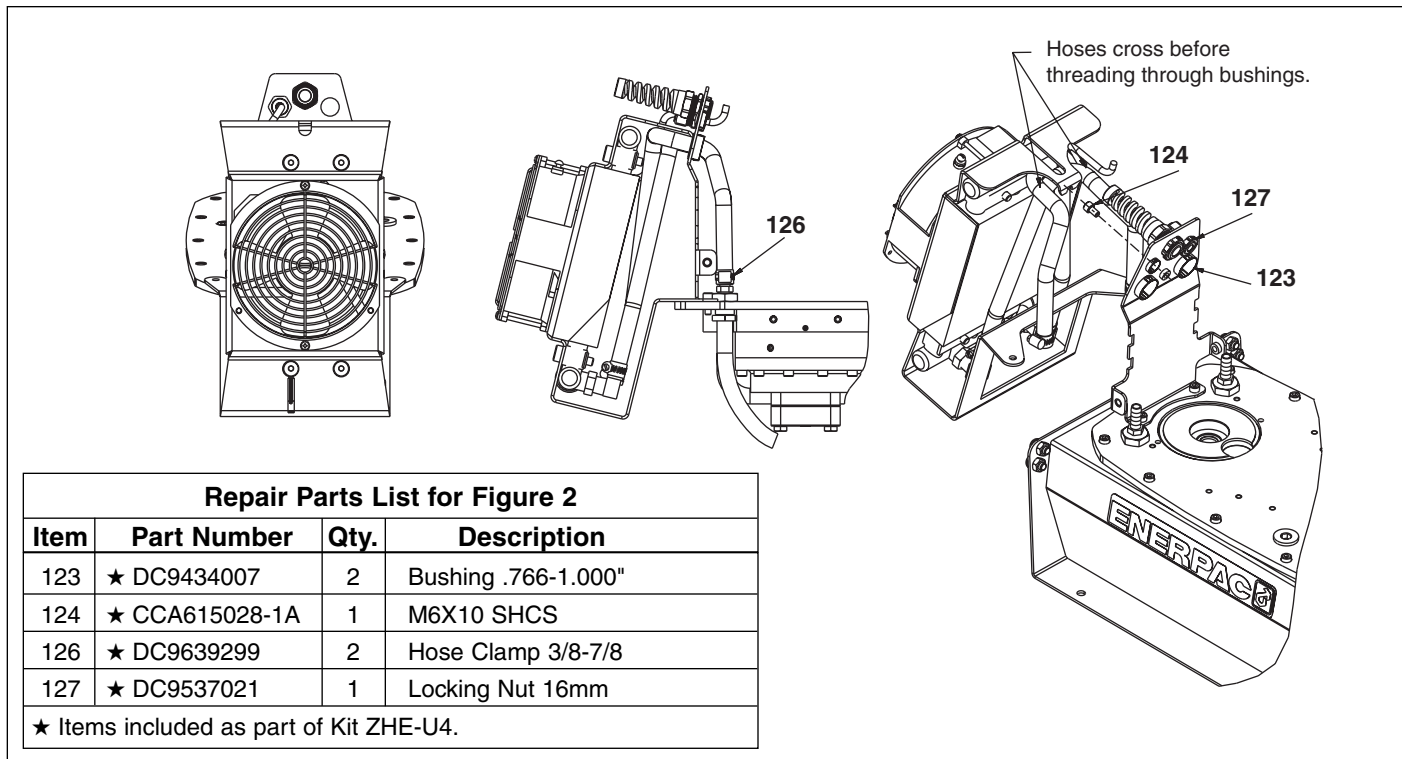

Figure 2, Heat Exchanger

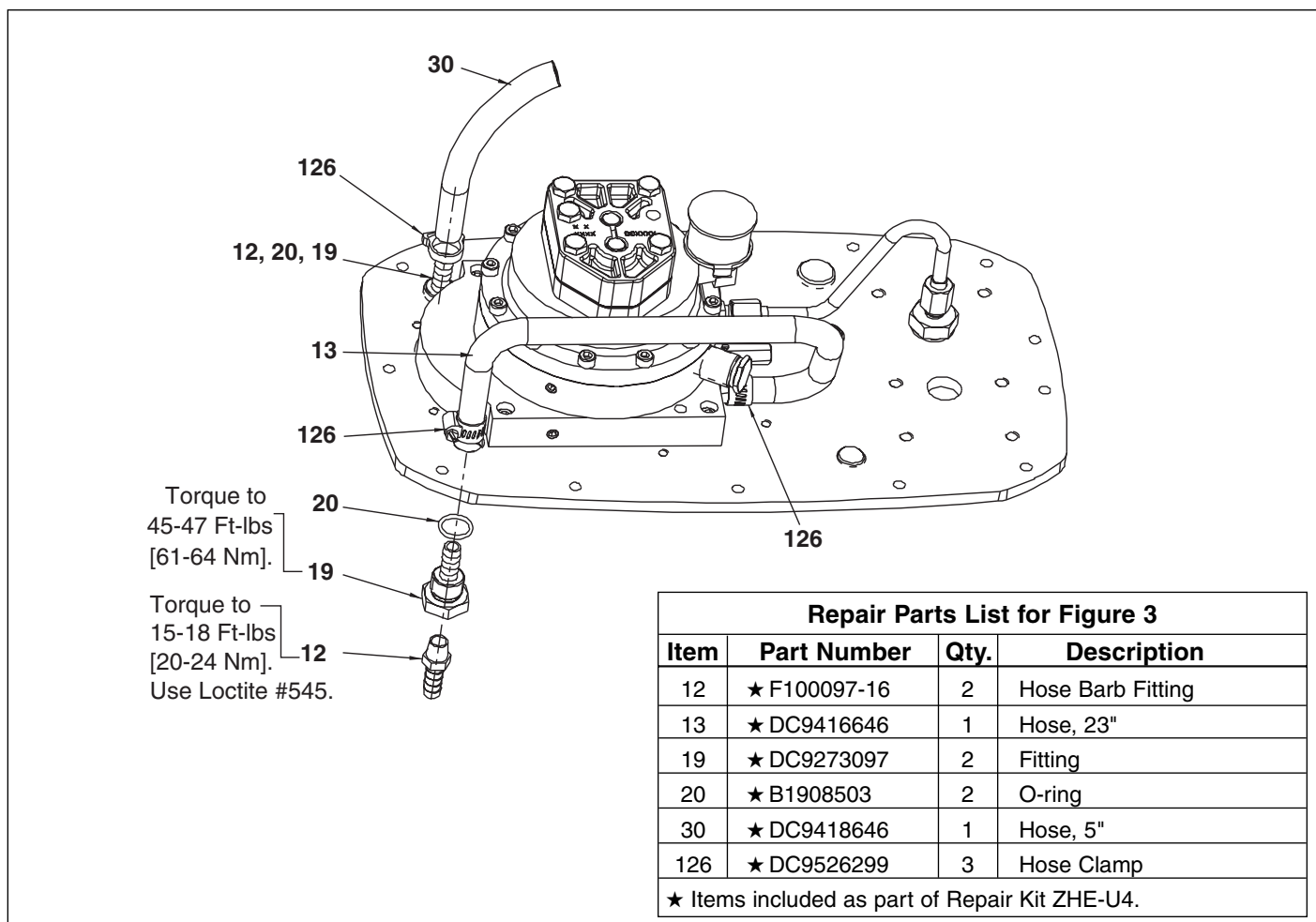

Figure 3, Heat Exchanger Cover Plate

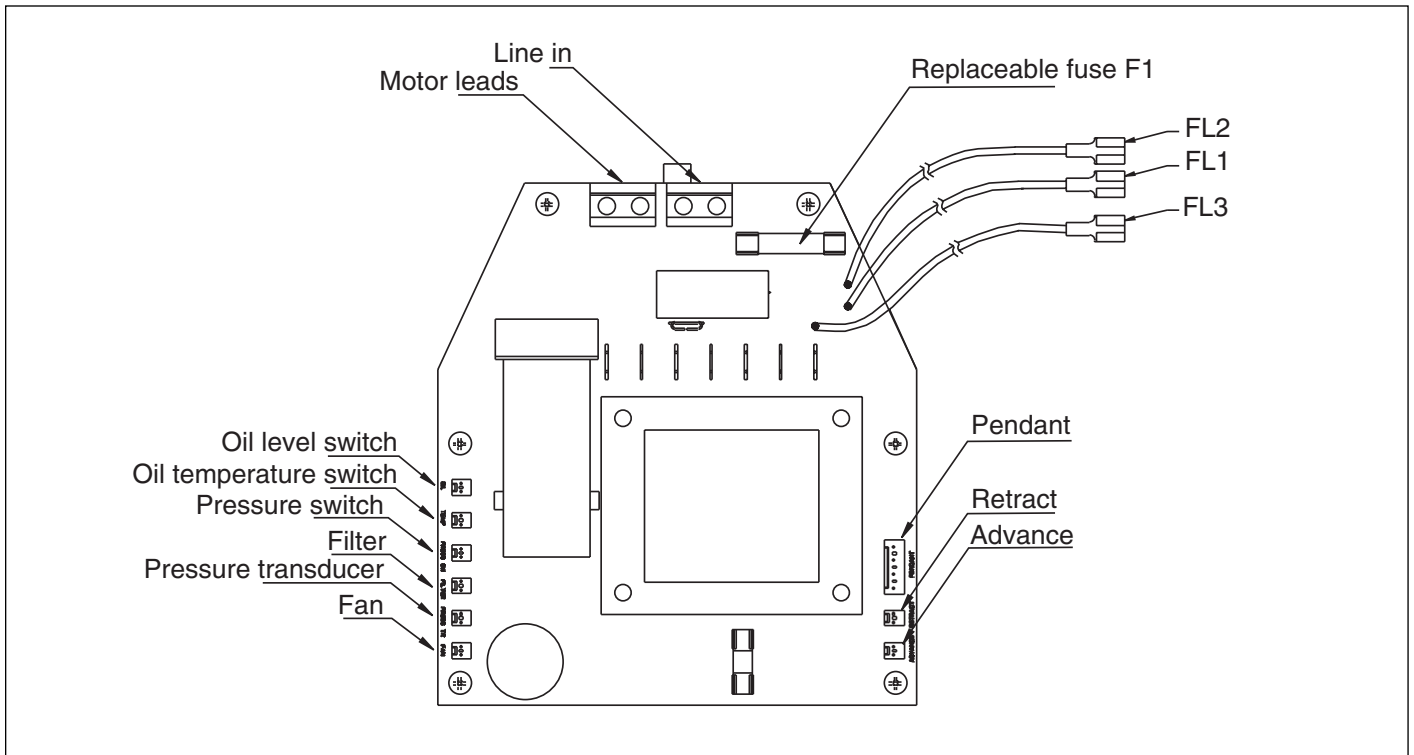

Figure 4, Power Board Wiring

ZHE-U4 HEAT EXCHANGER INSTALLATION INSTRUCTIONS

Be sure the pump is disconnected from the power source.

1. Remove the shroud from the cover plate by removing the nine screws and washers that hold the shroud together and to the cover plate with a 5 mm (3/16") Allen wrench.
2. The shroud half, with the controls, is wired to the pump and must be disconnected. On the LCD pump, gently pull away the connector for the ribbon cable. On the standard board you will need to remove the four power wires with a small flat screwdriver.
3. If needed, gently pull away any accessory connectors from the power board.
4. The pump can be removed from the reservoir without removing the motor or the valve.
5. Remove the 13 screws and gaskets that secure the cover plate to the reservoir using a 5 mm (3/16") Allen wrench.
6. Lift the cover plate up and remove it from the reservoir. The gasket may hold the cover plate firmly to the reservoir and it may require gentle prying with a flathead screwdriver to remove.
7. If the gasket is damaged, it will need to be replaced.
8. Remove the two SAE #8 plugs from the back of the cover plate.
9. Install the o-rings (item 20), the fittings (item 19), and the hose barbs (item 12) into the ports that the SAE #8 plugs were removed from (see Fig. 3).
10. Remove the 8" by-pass hose from the pump element.
11. Install the 23" hose from the pump element to the fitting (item 19) using two hose clamps (item 126) as show in Fig. 3.
12. Install the 5" hose to the remaining fitting (item 19) using one hose clamp (item 126) as shown in Fig. 3. This is the return hose.
13. The cover plate can now be re-installed to the reservoir using only 11 of the 13 screws. Torque to 50 – 60 inch lbs. Leave out the two back corner screws. They will be used to mount the heat exchanger bracket to the cover plate.
14. Slide a bushing (item 123, Fig. 2) on each hose. Cross the two hoses and insert the hose ends into the back bracket.
15. While keeping the bushings close to the top, route the hoses down, slide a hose clamp (item 126, Fig. 2) on each hose and press the hoses onto the hose barb (item 12, Fig. 3). Tighten the hose clamps.
16. Slide the bushings up and insert them into the back plate.
17. Assemble the heat exchanger to the pump. The heat exchanger is held on the pump by the two back corner screws left off earlier and one top screw (item 124, Fig. 2). Torque the cover plate screws to 50 - 60 inch lbs.
18. Route the fan cord through the back bracket as shown in Fig. 2. The cord bushing comes assembled on the cord. Using the lock nut (item 127, Fig. 2) fasten the cord bushing to the back bracket being careful not to over tighten the plastic lock nut (item 127).
19. Route the fan cord over the top of the motor and plug the connector into the fan pin on the power board. (see Fig. 4).
20. Re-assemble the shroud to the pump. Check for proper operation and leaks.

Enerpac Worldwide Locations

Africa

ENERPAC Middle East FZE
P.O. Box 18004
Jebel Ali, Dubai
United Arab Emirates
Tel: +971 (0)4 8872686
Fax: +971 (0)4 8872687

Australia

ENERPAC, Actuant Australia Ltd.
Block V Unit 3, Regents Park Estate
391 Park Road, Regents Park NSW 2143
(P.O. Box 261) Australia
Tel: +61 297 438 988
Fax: +61 297 438 648

Brazil

Power Packer do Brasil Ltda.
Rua dos Inocentes, 587
04764-050 - Sao Paulo (SP)
Tel: +55 11 5687 2211
Fax: +55 11 5686 5583
Toll Free in Brazil:
Tel: 0800 891 5770
vendabrasil@enerpac.com

Canada

Actuant Canada Corporation
6615 Ordan Drive, Unit 14-15
Mississauga, Ontario L5T 1X2
Tel: +1 905 564 5749
Fax: +1 905 564 0305
Toll Free:
Tel: +1 800 268 4987
Fax: +1 800 461 2456
Technical Inquiries:
techservices@enerpac.com

China

Actuant China Ltd.
1F, 269 Fute N. Road
Waigaoqiao Free Trade Zone
Pudong New District
Shanghai, 200 131 China
Tel: +86 21 5866 9099
Fax: +86 21 5866 7156

Actuant China Ltd. (Beijing)
709A Xin No. 2
Diyang Building
Dong San Huan North Rd.
Beijing City, 100028 China
Tel: +86 10 845 36166
Fax: +86 10 845 36220

Central and Eastern Europe

ENERPAC B.V.
Galvanistraat 115
P.O. Box 8097, 6710 AB Ede
The Netherlands
Tel: +31 318 535 936
Fax: +31 318 535 951

France

ENERPAC
Une division de ACTUANT France s.a.
B.P. 200
Parc d'Activités
du Moulin de Massy
F-91882 Massy CEDEX France
Tel: +33 1 601 368 68
Fax: +33 1 692 037 50

Germany, Austria, Szwitzerland, Russia, Greece and CIS (excl. Caspian Sea Countries)

ENERPAC Applied Power GmbH
P.O. Box 300113
D-40401 Düsseldorf
Germany
Tel: +49 211 471 490
Fax: +49 211 471 49 28

India

ENERPAC Hydraulics (India) Pvt. Ltd.
Plot No. A/571
MIDC, TTC Industrial Area
Mahape-400 701
Navi Mumbai, India
Tel: +91 22 2778 1472
Fax: +91 22 2778 1473

◆ e-mail: info@enerpac.com

Italy

ENERPAC S.p.A.
Via Canova 4
20094 Corsico (Milano)
Tel: +39 02 4861 111
Fax: +39 02 4860 1288

Japan

Applied Power Japan Ltd.
1-1-11, Shimomae
Toda-shi
Saitama Pref.
Japan 335-0016
Tel: +81 484 30 1055
Fax: +81 484 30 1066

The Netherlands, Belgium, Luxembourg, Sweden, Denmark, Norway, Finland, Baltic States

ENERPAC B.V.
Galvanistraat 115
P.O. Box 8097, 6710 AB Ede
The Netherlands
Tel: +31 318 535 911
Fax: +31 318 525 613
+31 318 535 848

Technical Inquiries Europe:

techsupport.europe@enerpac.com

Singapore

Enerpac Asia Pte. Ltd.
25 Serangoon North Ave. 5
#03-01 Keppel Digihub
Singapore 554914
Thomson Road
P.O. Box 114
Singapore 915704
Tel: +65 64 84 5108, +65 64 84 3737
1800 363 7722
Fax: +65 64 84 5669
Technical Inquiries:
sales@enerpac.com.sg

South Korea

Actuant Korea Ltd.
3Ba 717, Shihwa Industrial Complex,
Jungwang-Dong, Shihwa-Shi, Kyunggi-Do
Republic of Korea 429-450
Tel: +82 31 434 4506
Fax: +82 31 434 4507

◆ internet: www.enerpac.com

Spain, Portugal

ENERPAC
C/San José Artesano 8
Pol. Ind.
28108 Alcobendas
(Madrid) Spain
Tel: +34 91 661 11 25
Fax: +34 91 661 47 89

Middle East, Turkey , Caspian Sea

ENERPAC Middle East FZE
P.O. Box 18004
Jebel Ali, Dubai
United Arab Emirates
Tel: +971 (0)4 8872686
Fax: +971 (0)4 8872687

United Kingdom, Ireland

ENERPAC Ltd., P.O. Box 33
New Romney, TN28 8QF
United Kingdom
Tel: +44 1527 598 900
Fax: +44 1527 585 500

USA, Latin America and Caribbean

ENERPAC
P.O. Box 3241
6100 N. Baker Road
Milwaukee, WI 53209 USA
Tel: +1 262 781 6600
Fax: +1 262 783 9562

User inquiries:

+1 800 433 2766

Distributor inquiries/orders:

+1 800 558 0530

Technical Inquiries:

techservices@enerpac.com

All Enerpac products are guaranteed against defects in workmanship and materials for as long as you own them.
For your nearest authorized Enerpac Service Center, visit us at www.enerpac.com